

Installation and maintenance manual

ELECTROMECHANICAL TRIM TABS

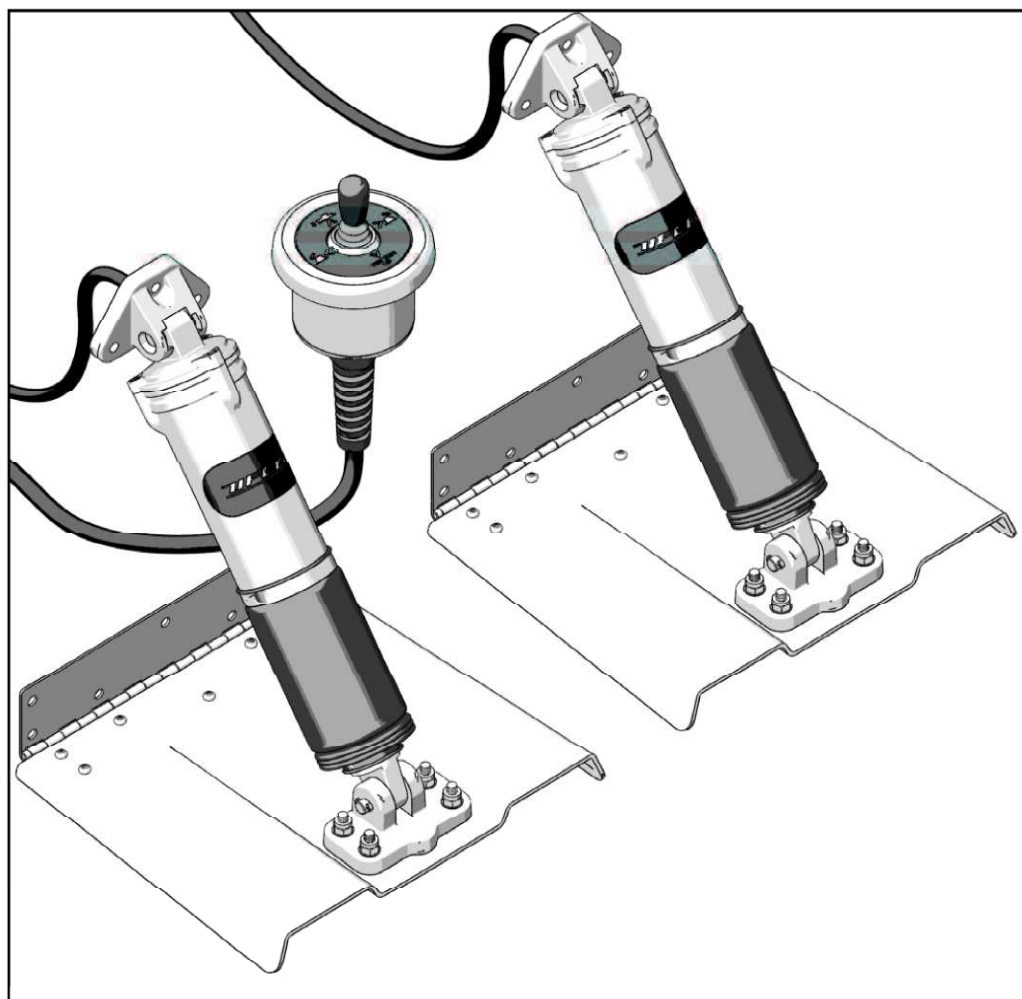

ULTRAFLEX



UK
page 2



PARTNER

MEMBER
ABYC
Setting Standards for Safer Boating®

I
pag. 29



F
page 57

ENGLISH

ITALIANO

FRANÇAIS



ULTRAFLEX GROUP

(Dr./Dis./Des. n° 28598/E 09/04/2015)



Dear Customer,

UFLEX trim tabs are manufactured by **ULTRAFLEX** a company belonging to **ULTRAFLEX GROUP**. **ULTRAFLEX GROUP** has been a leader in accessory manufacture for pleasure and professional boats for many years.

ULTRAFLEX production is since ever synonymous with reliability and safety. All **ULTRAFLEX** products are designed and manufactured to ensure the best performance.

The **ULTRAFLEX** quality management system involves all the company resources and processes starting from the design, in order to:

- ensure product quality to the customer;
- maintain and improve the quality standards constantly;
- pursue a continuous process improvement to meet the market needs and to increase the customer satisfaction;
- constantly test the products to verify their conformity with the CE directives, and with ISO and ABYC (American Boat and Yacht Council) standards.

To keep your safety and to maintain always a high quality level, **UFLEX** guarantees its products only if they are used with original spare parts.



TABLE OF CONTENTS

MANUAL USE AND SYMBOLS USED.....	4
INFORMATIVE LETTER.....	5
WARRANTY.....	5

SECTION 1 - PRODUCT DESCRIPTION

1.1 TRIM TAB DESCRIPTION.....	6
1.2 OPERATION.....	6
1.3 ACTUATOR DIMENSIONS.....	7
1.4 EASY-JOY CONTROL DIMENSIONS.....	7
1.5 TAB TECHNICAL FEATURES.....	8

SECTION 2 - TRANSPORT

2.1 GENERAL WARNINGS.....	9
2.2 PACKAGING.....	9

SECTION 3 - INSTALLATION

3.1 NECESSARY TOOLS.....	11
3.2 TAB INSTALLATION.....	11
3.3 EASY-JOY CONTROL INSTALLATION.....	15
3.3.1 EASY-JOY CONTROL POSITIONING.....	15

SECTION 4 - WIRINGS

4.1 GENERAL NOTES.....	16
4.2 CABLE IDENTIFICATION.....	16
4.3 WIRING DIAGRAMS.....	17
4.3.1 ACTUATOR CONNECTION.....	18
4.3.2 AUTO LINE-UP.....	19
4.3.3 CONNECTION OF THE SECOND EASY JOY CONTROL STATION	21

SECTION 5 - USE

5.1 USE.....	22
5.2 SAFETY RULES DURING USE.....	24

SECTION 6 - MAINTENANCE

6.1 ORDINARY MAINTENANCE.....	25
-------------------------------	----

SECTION 7 - DISMANTLING

7.1 DISMANTLING.....	26
----------------------	----

MANUAL USE AND SYMBOLS USED

THE INSTALLATION AND MAINTENANCE MANUAL is the document accompanying the product from its sale to its replacement and dismantling. The manual is an important part of the product.

It is necessary to read carefully the manual, before ANY ACTIVITY involving the product, handling and unloading included.

In this manual the following symbols are used to ensure the user safety and to guarantee the correct operation of the product:

 **DANGER** → Immediate hazards which CAUSE severe personal injury or death.

 **WARNING** → Denotes that a hazard exists which can result in injury or death if proper precautions are not taken.

 **CAUTION** → Denotes a reminder of safety practices or directs attention to unsafe practices which could result in personal injury or damage to the craft or components or to the environment.

NOTICE → Important information for the correct installation and for maintenance, that does not cause any damage.

 → The symbol aside indicates all the operations which must be carried out by qualified or skilled staff, in order to avoid hazards. We recommend training the staff in charge of the product installation and checking their knowledge.

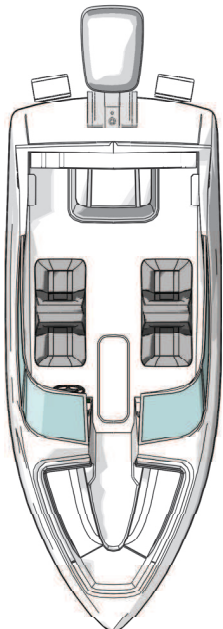
STARBOARD  **PORT** → The picture aside explains the meaning of some nautical words contained in this manual.

STERN

BOW



INFORMATIVE LETTER

This installation and maintenance manual represents an important part of the product and must be available to the people in charge of its use and maintenance.

The user must know the content of this manual.

UFLEX declines all responsibility for possible mistakes in this manual due to printing errors.

Apart from the essential features of the described product, **UFLEX** reserves the right to make those modifications, such as descriptions, details and illustrations, that are considered to be suitable for its improvement, or for design or sales requirements, at any moment and without being obliged to update this publication.

ALL RIGHTS ARE RESERVED. Publishing rights, trademarks, part numbers and photographs of **UFLEX** products contained in this manual are **UFLEX** property.

Great care has been taken in collecting and checking the documentation contained in this manual to make it as complete and comprehensible as possible. Nothing contained in this manual can be interpreted as warranty either expressed or implied - including, not in a restricted way, the suitability warranty for any special purpose. Nothing contained in this manual can be interpreted as a modification or confirmation of the terms of any purchase contract.

WARNING

To ensure the correct product and component operation, the product must be installed by qualified staff. In case of part damage or malfunction, please contact the qualified staff or our Technical Assistance Service.

TECHNICAL ASSISTANCE SERVICE

UFLEX S.r.l.

Via Milite Ignoto,8A
16012 Busalla (GE)-Italia
Tel: +39.010.962.0239 (Italia)
Tel: +39.010.962.0244 (Estero)
Fax: +39.010.962.0333
Email: ut@ultraflexgroup.it
www.ultraflexgroup.it

North - South - Central America: **UFLEX USA**

6442 Parkland Drive
Sarasota, FL 34243
Tel: +1.941.351.2628
Fax: +1.941.360.9171
Email: uflex@uflexusa.com
www.uflexusa.com

WARRANTY

UFLEX guarantees that its products are well designed and free from manufacturing and material defects, for a period of two years from the date of manufacturing.

For the products which are installed and used on working or commercial boats the warranty is limited to one year from the date of manufacturing.

If during this period the product proves to be defective due to improper materials and/or manufacture, the manufacturer will repair or replace the defective parts free of charge.



Direct or indirect damage is not covered by this warranty. In particular the company is not responsible and this warranty will not cover the damage resulting from incorrect installation or use of the product (except for replacement or repair of defective parts according to the conditions and terms above).

This warranty does not cover the products installed on race boats or boats used in competitions.

The descriptions and illustrations contained in this manual should be used as general reference only. The warranty is valid only if **UFLEX** trim tabs are used with **UFLEX** control units.

For any further information please contact our Technical Assistance Service.

UFLEX trim tabs manufactured by **ULTRAFLEX** are marked  according to the Directive 2013/53/EU.

We remind you that only  marked connection systems must be used on the boats marked .

We inform you that the **UFLEX** warranty is null if some **UFLEX** system components are replaced by components of other brands.



1 PRODUCT DESCRIPTION

1.1 Trim tab description

ENGLISH

The use of the tabs allows the boat to maintain an adequate trim according to the different navigation conditions, optimizing the performance. If necessary (Pict.1), the tab drive rectifies and rebalances the boat trim (Pict. 2), ensuring a higher motor efficiency and speed, a considerable fuel saving and navigation safety. The tabs fixed to the lower edge of the transom act as a movable extension of the boat hull, increasing the stability in several conditions.

Their working principle is the following: the water, flowing on the tab surface, causes the stern lifting as the tab is lowered. According to this principle, it is possible to change the tab lowering up to reaching a trim that can ensure an optimal performance for each situation.

The trim tabs described in this manual are made up of:

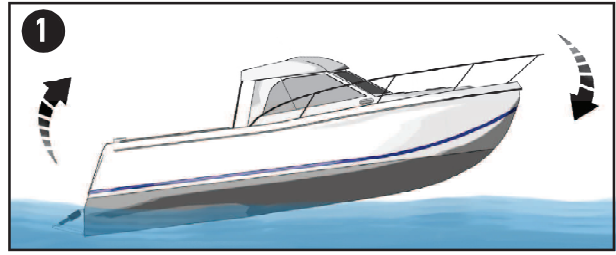

- 1 Actuator
- 2 Connection bracket to the transom
- 3 Electric cable (2 m)
- 4 Connection bracket to the tab
- 5 Tab + hinge
- 6 Easy-Joy - Control system

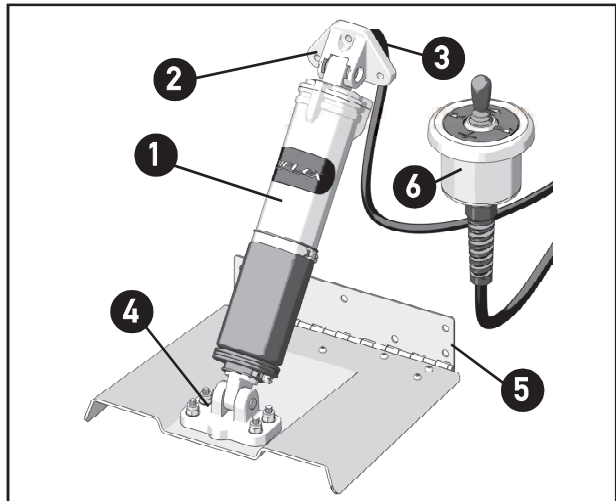

1.2 Operation

The joystick allows an easy use of the Trim Tab system. Thanks to this control system, the user can focus on the boat trim, regardless of the tab position.

The electromechanical actuators (2) that allow changing the inclination angle of tab (3) are controlled by means of **Easy-Joy** (1) that is located on the dashboard or on the upper station.

Easy-Joy function description:

- By jogging the lever forward, the boat bow goes down;
- By jogging the lever backward, the boat bow goes up;
- By jogging the lever rightward, the boat tilts to starboard
- By jogging the lever leftward, the boat tilts to port

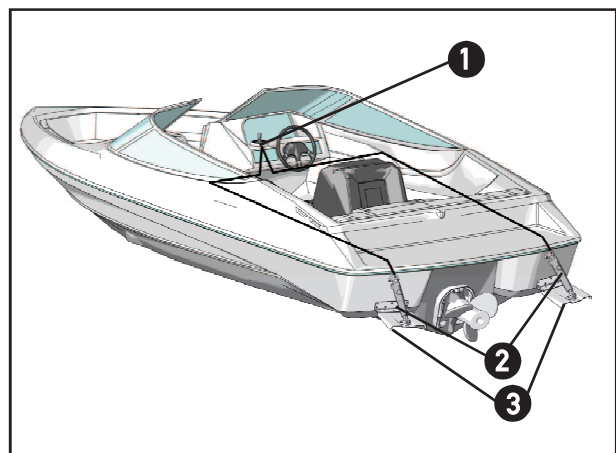

When running at idle or when the engine turns off, the electronic system enables the AUTO LINE-UP function automatically. It allows putting the tabs in rest position.



1.3 Actuator dimensions

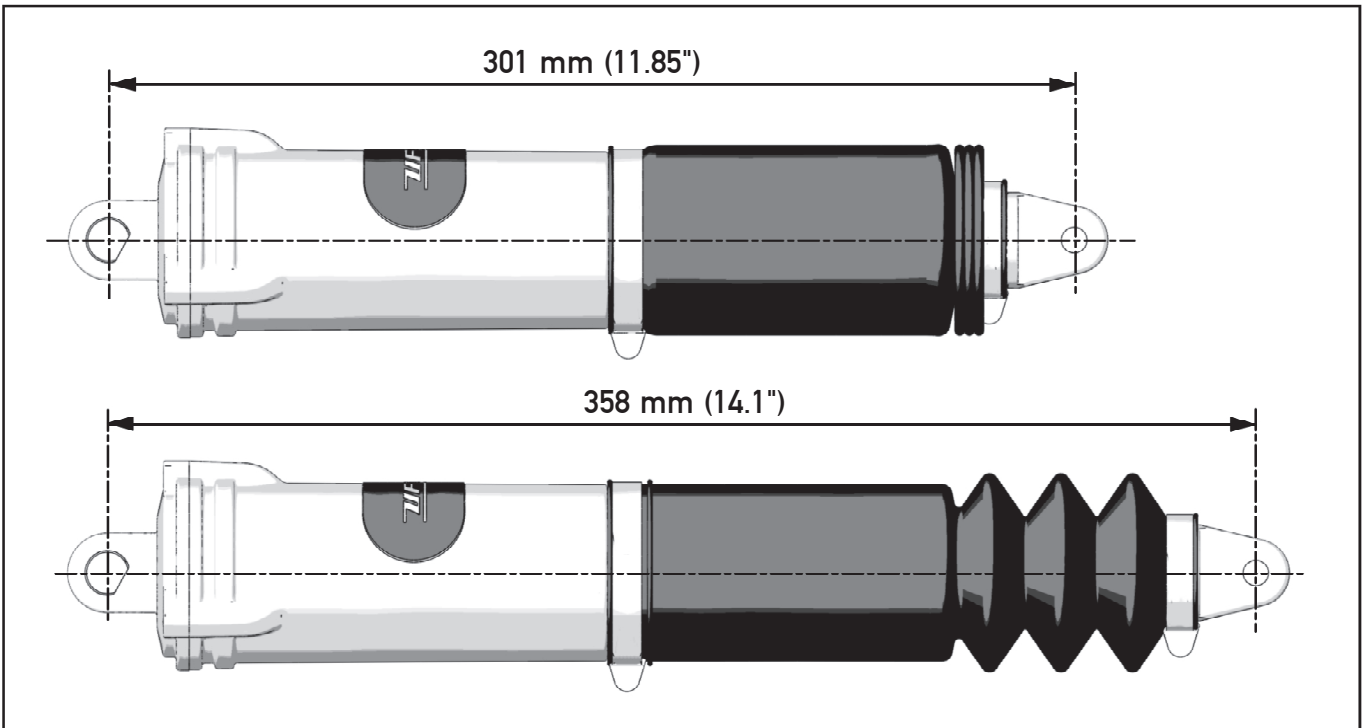

1.4 Easy-Joy control dimensions

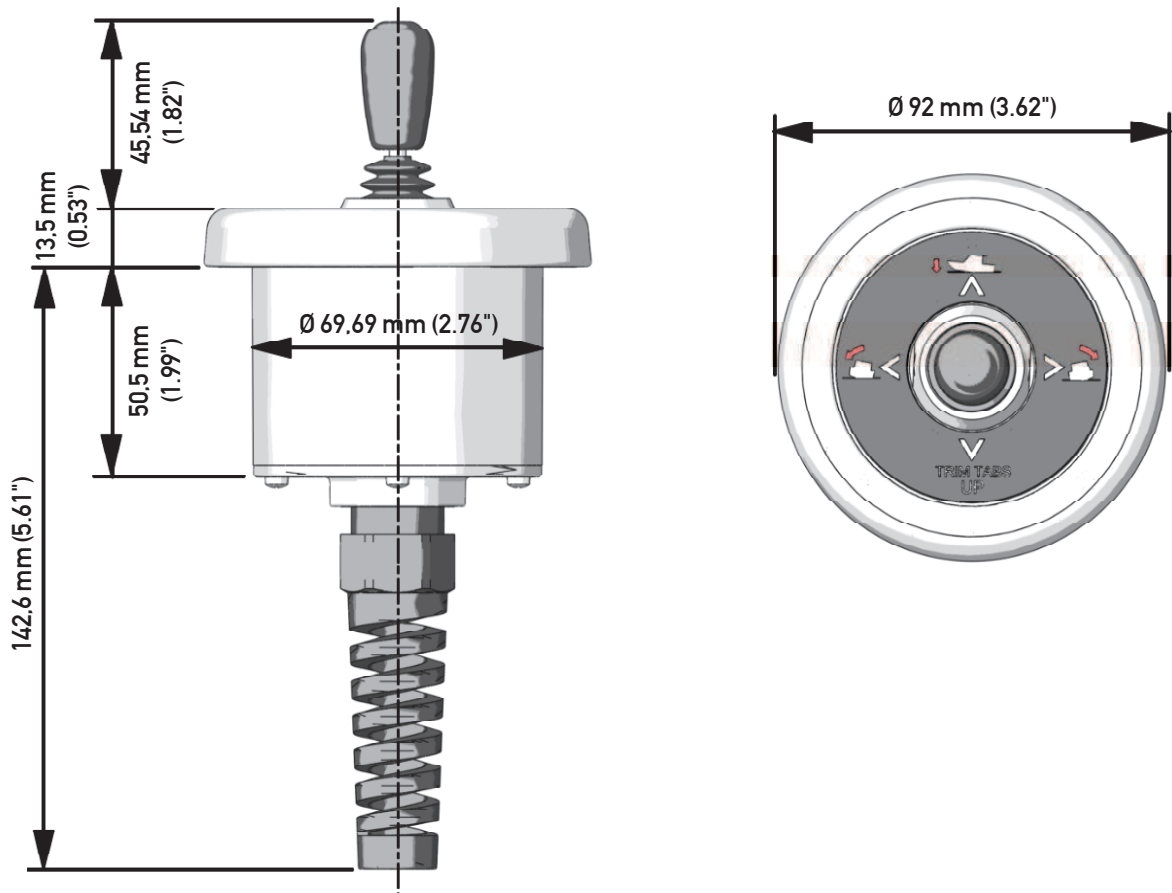

1.5 Tab technical features

ENGLISH

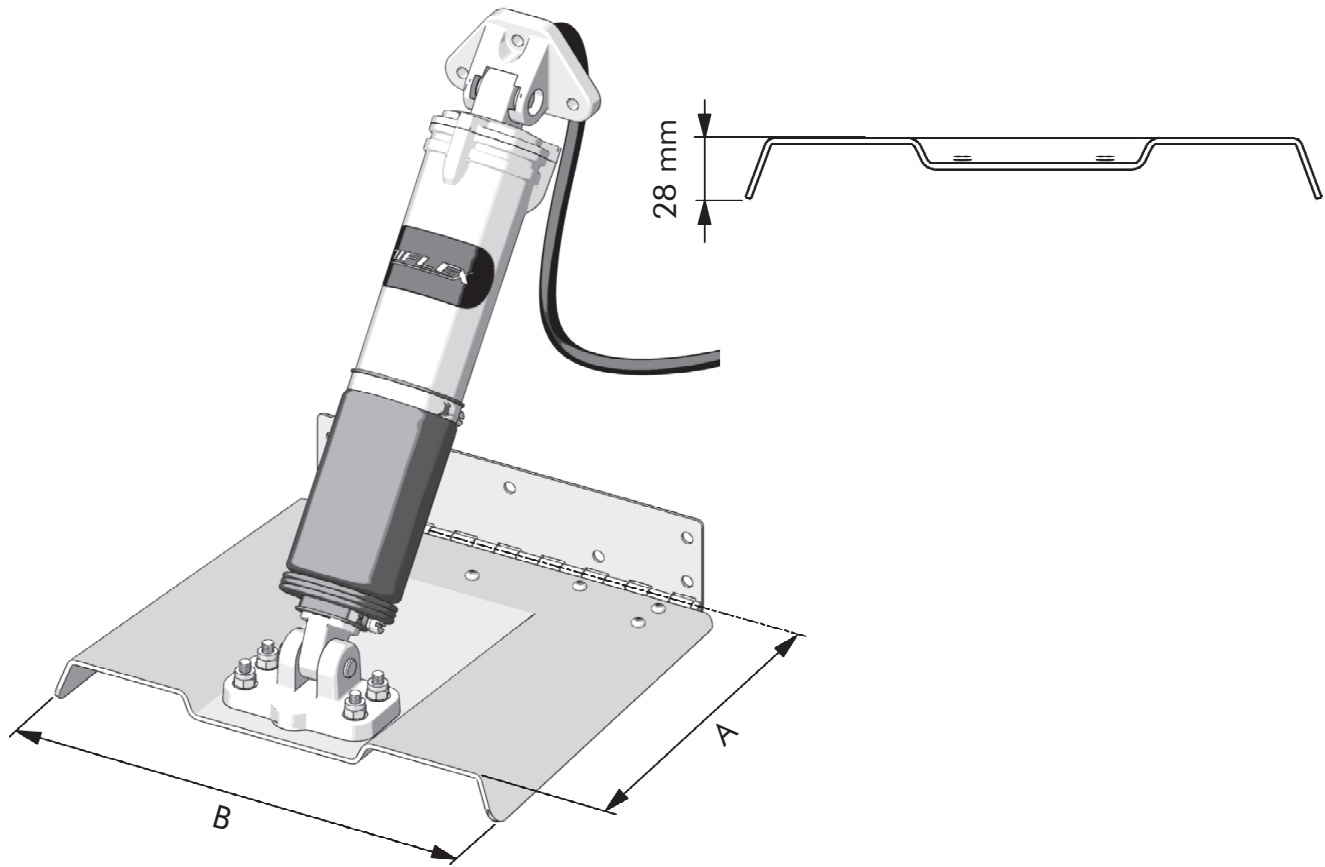

"STANDARD" ASSEMBLY				
A inches/mm	9" (229mm)	12" (305mm)	12" (305mm)	12" (305mm)
B inches/mm	9" (229mm)	9" (229mm)	12" (305mm)	18" (457mm)



2 TRANSPORT

2.1 Special warnings

Since the weight of the product with its packaging is lower than 20 Kg, it can be handled manually.

⚠ WARNING

The staff in charge of handling the load must work with protective gloves and safety shoes.

2.2 Packaging

Before using the appliance, check there is no damage due to transport or storage conditions. Furthermore, check that all the standards components are inside the packaging (see the list). In case of damage, make a complaint to the carrier and inform the supplier. Inside the packaging there are the following components:

MASTER PACKAGING

- 1** Two single-packed actuators with brackets, screws and 2m of electric cable each
- 2** Easy-Joy control unit packed with 0.5 m of cable and fixing screws
- 3** Installation manual

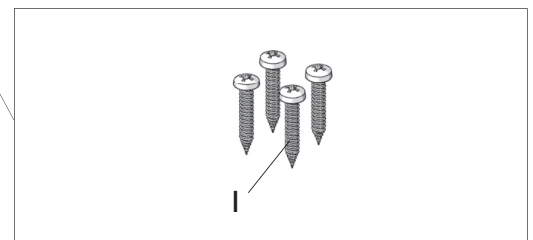
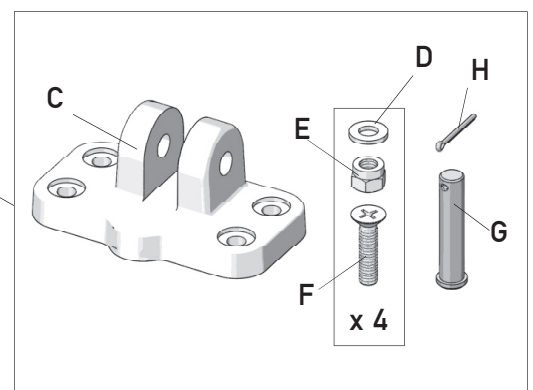
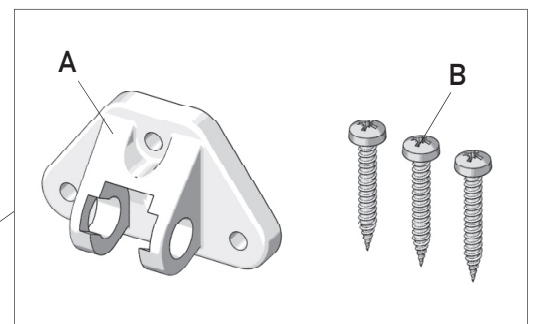
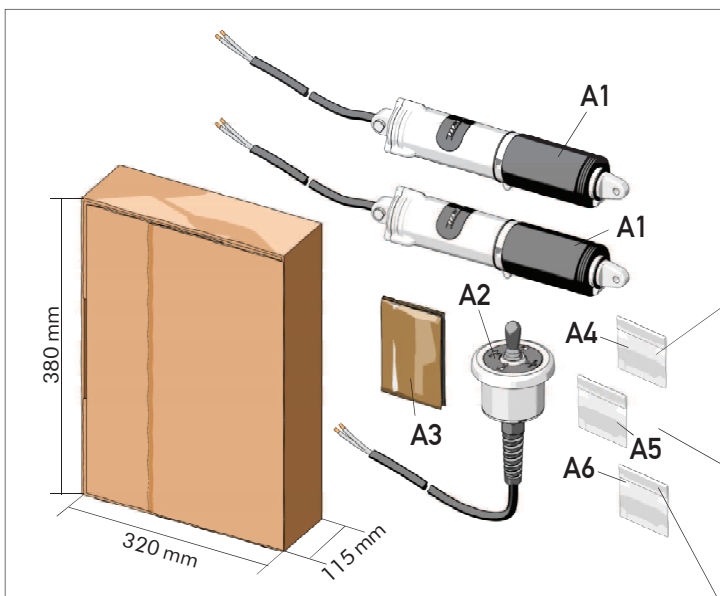

Ref.	Component	Qty.
A1	Electromechanical actuator	2
A2	Easy-Joy Joystick	1
A3	Installation manual	1
A4	Bag for upper bracket	2
A5	Bag for lower bracket	2
A6	Bag for Joystick	1
A	Upper bracket	2
B	Self-tapping screw ST 6.3x32	6
C	Lower bracket	2
D	Washer	8
E	Self-locking nut	8
F	Screw M6 x 20	2
G	Pin	2
H	Split pin	8
I	Screw ST2.9x13	4



TAB PACKAGING

- 1 Two tabs with the bag containing fixing screws

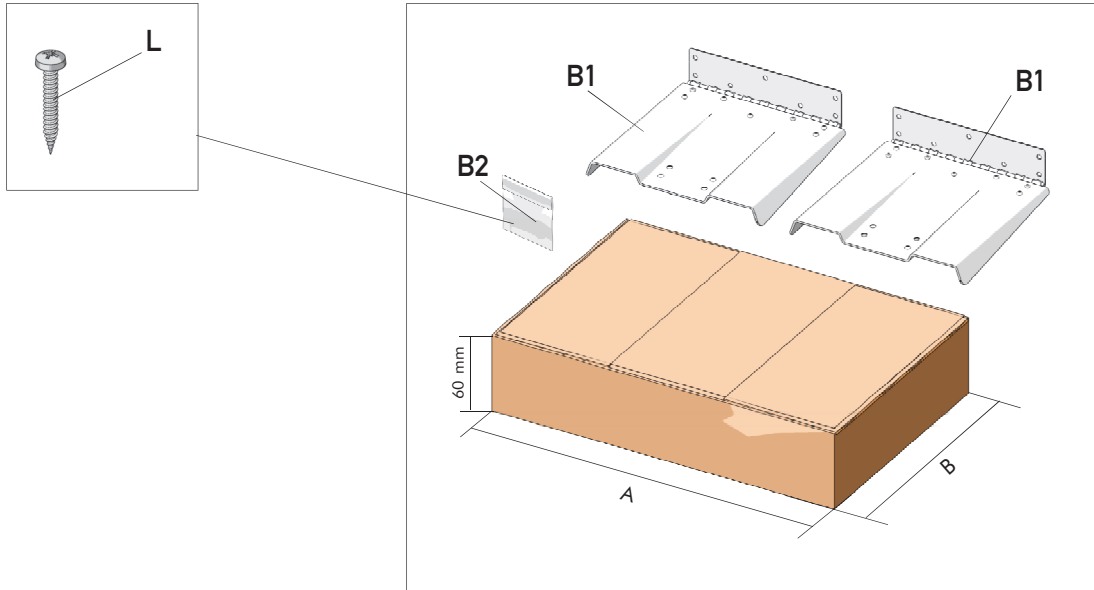

Ref.	Component	Qty.
B1	Tab	2
B2	Fixing screw bag	1
L	Self-tapping screws ST6.3x32	NOTICE

NOTICE

For a correct installation, use all the screws provided in the packaging (7 for tabs 9"x9" and 12"x9", 8 for tabs 12"x12", 11 for tabs 12"x18").

TAB PACKAGING DIMENSIONS				
	9"x9"	12"x9"	12"x12"	12"x18"
A	360 mm (14,17")	360 mm (14,17")	360 mm (14,17")	510 mm (20,07")
B	325 mm (12,79")	325 mm (12,79")	325 mm (12,79")	325 mm (12,79")

CAUTION

The packaging must be disposed of according to the laws in force.



3 INSTALLATION

3.1 Necessary tools

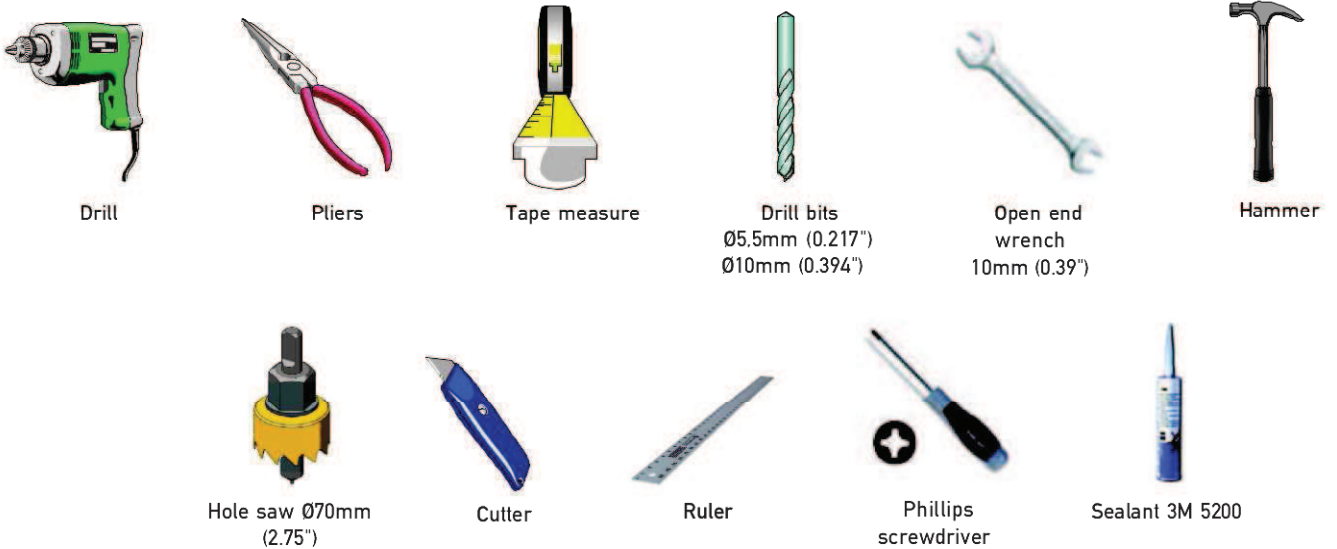

3.2 Tab installation



- 1 Find the tab installation point as shown in the picture.

⚠ WARNING

Make sure the upper fixing bracket (A) of the actuator is not near other devices in the inner part of the transom obstructing the passage of the power cable.

Place the tab hinge at a minimum distance of 200mm (8") from the boat center line, at 25-100mm (1-4") from the side edge of the keel and at 10mm (3/8") from the bottom part of the hull. If there are some steps in the bottom part of the boat, the hinge must be positioned at a distance of at least 50mm (2") from the top of the fairing.

Make sure the hinge is parallel to the bottom part of the hull. Moreover, for a correct installation, the side corner of the hinge must be at a minimum distance of 50 mm from the fairing.

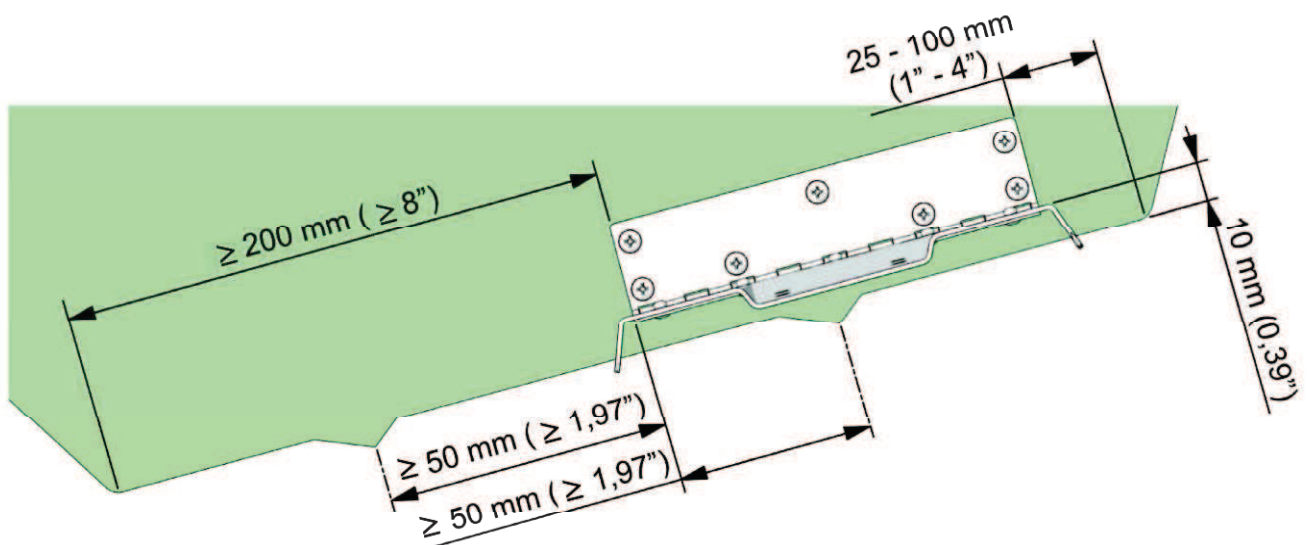

2 NOTICE

In order to ensure a correct installation of the tabs, use the bigger holes (indicated by ● in the picture) on the hinge plate.

NOTICE

The smaller holes (indicated by ○ in the picture) are used for an installation replacing other systems.

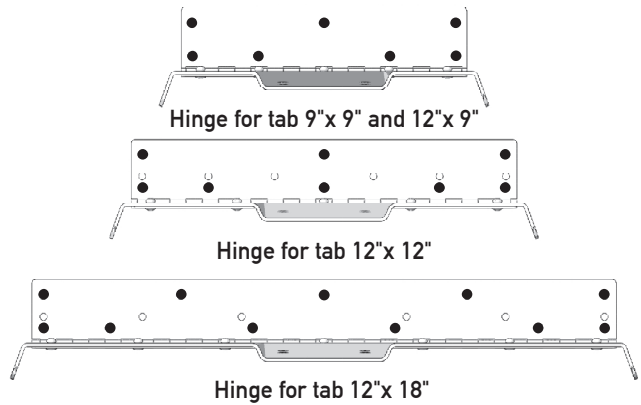

3 After placing the hinge on the boat stern and after checking all the proper measures, mark the hole position. Make the preholes with a Ø5,5 mm (0.217") drill tip with a depth of 32 mm (1.26") max.

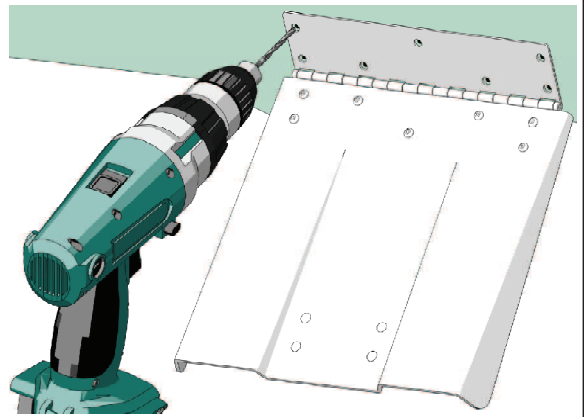

4 Put sealant 3M 5200 into the preholes and fix the hinge to the transom by using the supplied self-tapping screws (L). Once the hinge has been fixed, put some sealant 3M 5200 on its perimeter.

NOTICE

All the supplied screws are made up of stainless steel. Do not use any other kind of material.

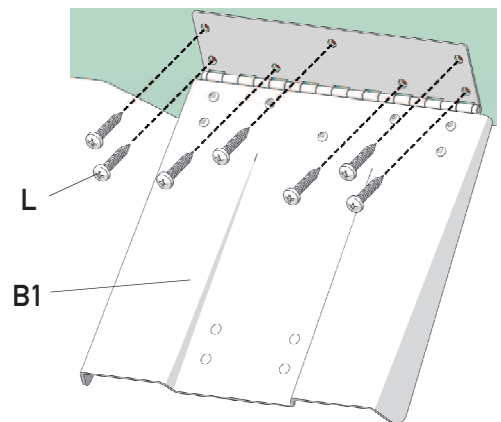

5 For the fixing, put bracket (C) on tab (B1), insert screws (F) through the holes of the tab and bracket (C), put washer (D) and tighten the self-locking nut (E).

NOTICE

Make sure the bracket projecting part is directed to the opposite side of the boat stern.

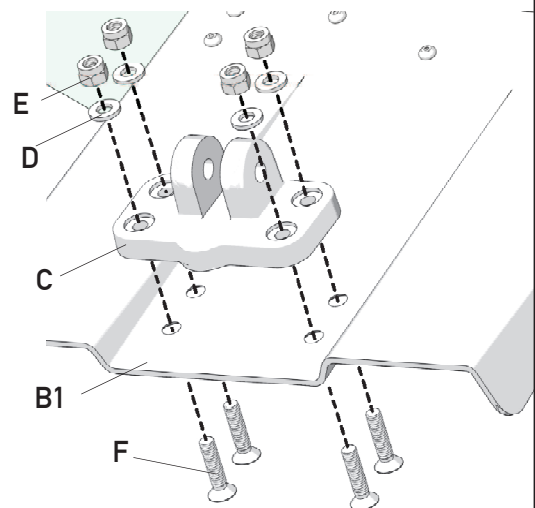

6 Fix the actuator end fitting to bracket (C) inserting pin (G) and locking it by means of the split pin (H).

NOTICE

The actuator (A1) is supplied in 0 mm stroke position in order to be installed properly. Do not power it since this would cause the actuator to change its position.

⚠ WARNING

The bracket must be installed exactly as shown in the picture.

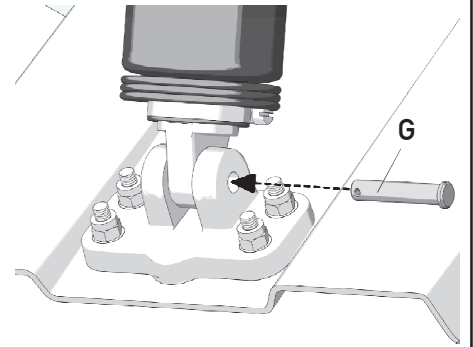

7 Insert the upper bracket (A) on actuator (A1), WITHOUT inserting the cable through the bracket in order to mark its perimeter.

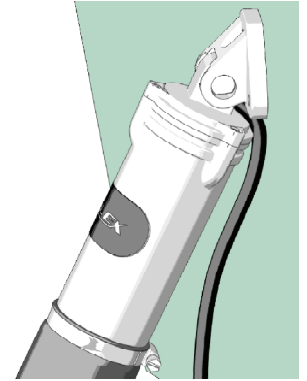

8 Place the upper bracket (A) on the transom.

For a correct installation, lift the outer edge of the tab according to the measures which are shown in the following table.

INSTALLATION DISTANCE	
A	B
9"	19,5 mm (0.77")
12"	21 mm (0.83")

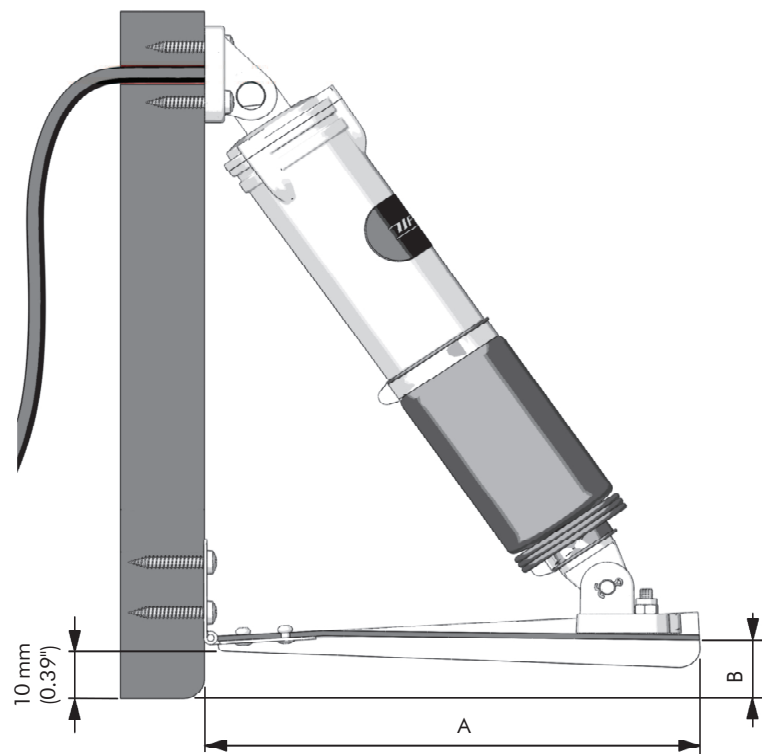

9 Remove the upper bracket (A) from actuator (A1) and place it on the transom in order to mark the hole position and the bracket outline by using a pencil or a pen.

NOTICE

Make sure the cable hole is properly positioned.

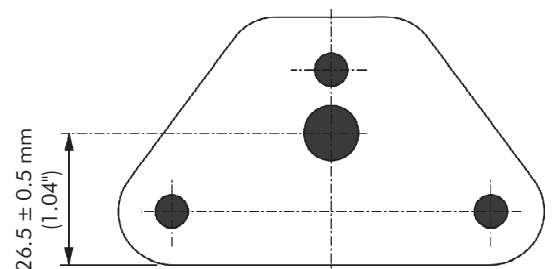

10 Make three Ø 5.5 mm (0.22") holes with maximum depth of 25 mm (0.98") to fix bracket (A) and Ø 10mm (0.39") (through) central hole to allow the passage of the power cable.

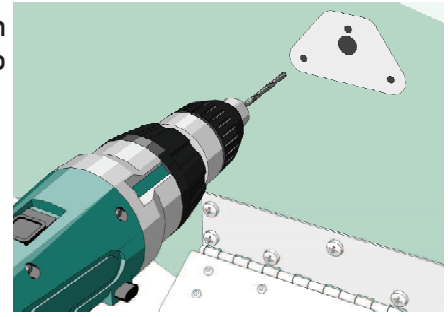

11 Insert the actuator (2) power cable (1) into the central hole. Then put the actuator on the upper bracket (3). Insert the power cable into the transom hole. Place the bracket as close as possible to the transom and seal the cable passage hole, the rear part of the bracket and the preholes of the fixing screws using sealant 3M 5200 as explained in the product instructions.

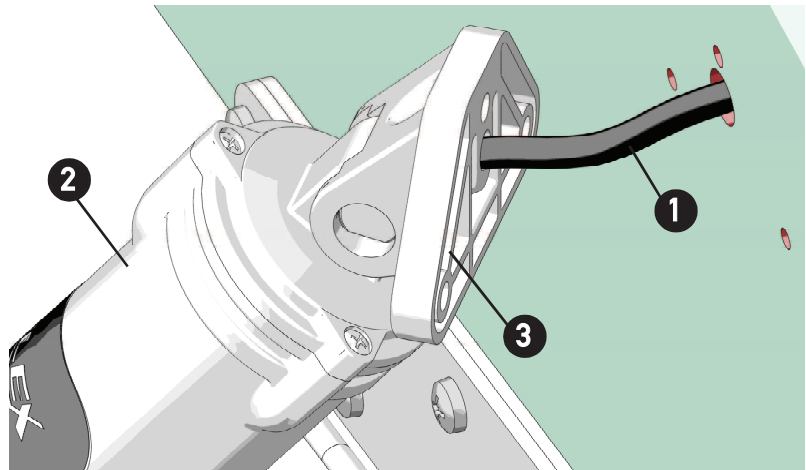

12 Fix the upper bracket (3) by means of the supplied screws. Wait for the sealant 3M 5200 to dry as explained in the product instructions (generally 24-48 hours).

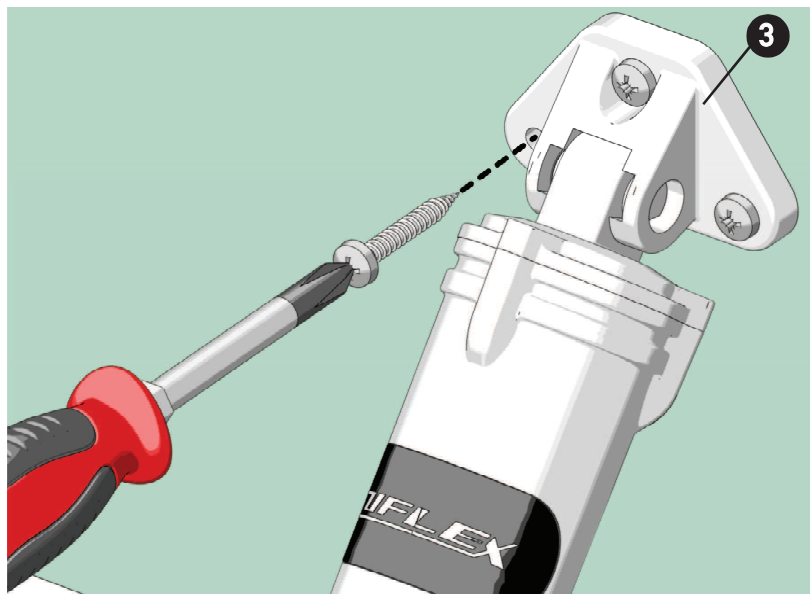



3.3 Easy-Joy control installation

3.3.1 Easy-Joy control positioning

1 Position the control panel so that it does not hinder other controls or that it is not hindered by them.

2 Refer to the overall dimensions indicated in paragraph 1.4 to make sure the Easy-Joy panel can be installed in the chosen position.

3 After choosing the right position, make the hole to insert the control panel with the suitable template.

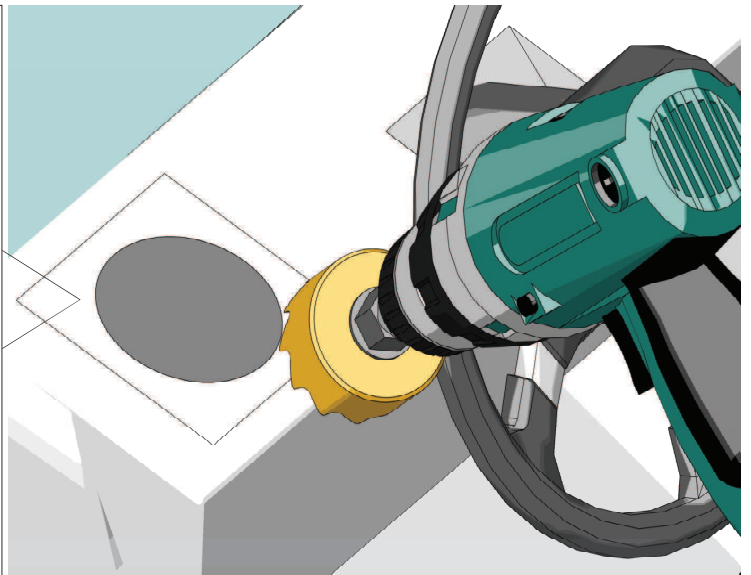
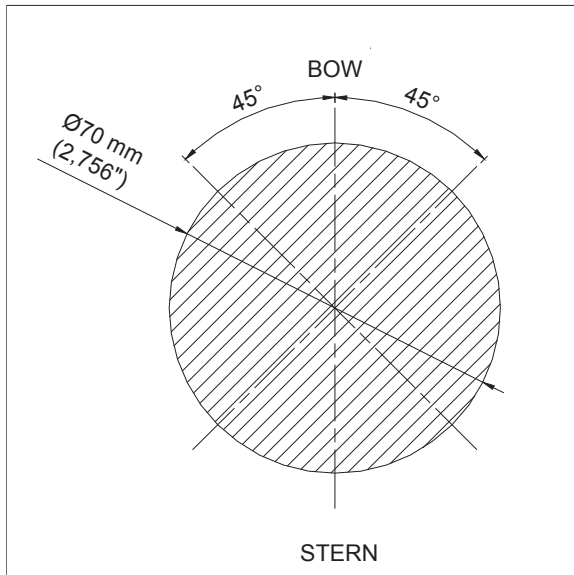

4 Before fixing the Easy-joy to the dashboard, connect the electric cables following the instructions of chapter 5.

5 Unscrew the chromium plated ring nut counterclockwise, insert the joystick in its seat on the dashboard and, by means of the four self-tapping screws (I), insert the chromium plated ring nut completely and turn it clockwise until it is properly locked.

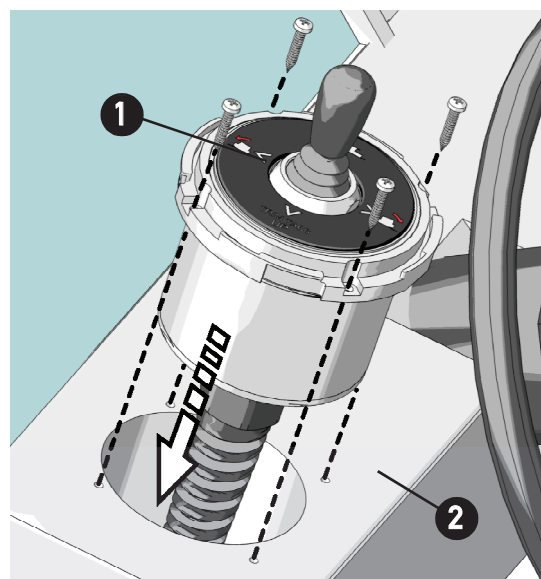
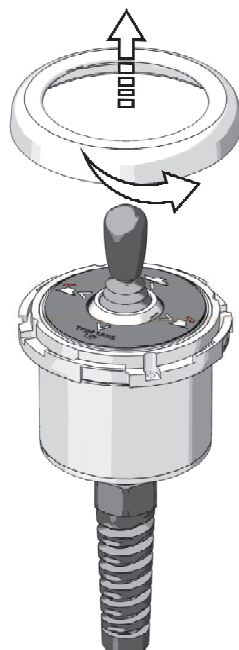

4 WIRINGS

4.1 General notes

ENGLISH

WARNING

UFLEX is not to be held responsible for possible damages or malfunctions deriving from operation not workmanlike performed.

The extension power cables supplied by **UFLEX** are high-quality, saltiness- and oil-resistant cables. In case an extension power cable is not long enough, replace it with a longer one.

WARNING

The extension cables supplied by **UFLEX** are highly water-proof to be assembled in places subjected to salty water sprays.

The electric cable wiring must be performed by skilled staff. The electric connections must be properly waterproofed to avoid oxidation on conductors.

4.2 Cable identification

The following table allows a quick consultation on the electric conductors and their use

Conductor colour		Use	Conductor section
Red	V bat	Power positive wire	AWG 14
Black	GND	Power negative wire (ground)	AWG 14
White/Green	STBD+	Starboard actuator power (positive)	AWG 16
White/Red	PORT+	Port actuator power (positive)	AWG 16
Black/Green	STBD-	Starboard actuator power (negative)	AWG 16
Black/Red	PORT-	Port actuator power (negative)	AWG 16
Orange	KEY	Engine key	AWG 18
Orange/White	NSAF-	Neutral safety (Negative)	AWG 18
Orange/Black	NSAF+	Neutral safety (Positive)	AWG 18
Blue	COM	Second station connection	AWG 18
Yellow	UP	Second station connection	AWG 18
Grey	DOWN	Second station connection	AWG 18
Purple	LEFT	Second station connection	AWG 18
Green	RIGHT	Second station connection	AWG 18



4.3 Wiring diagrams

The following picture shows the product wiring diagram.

ENGLISH

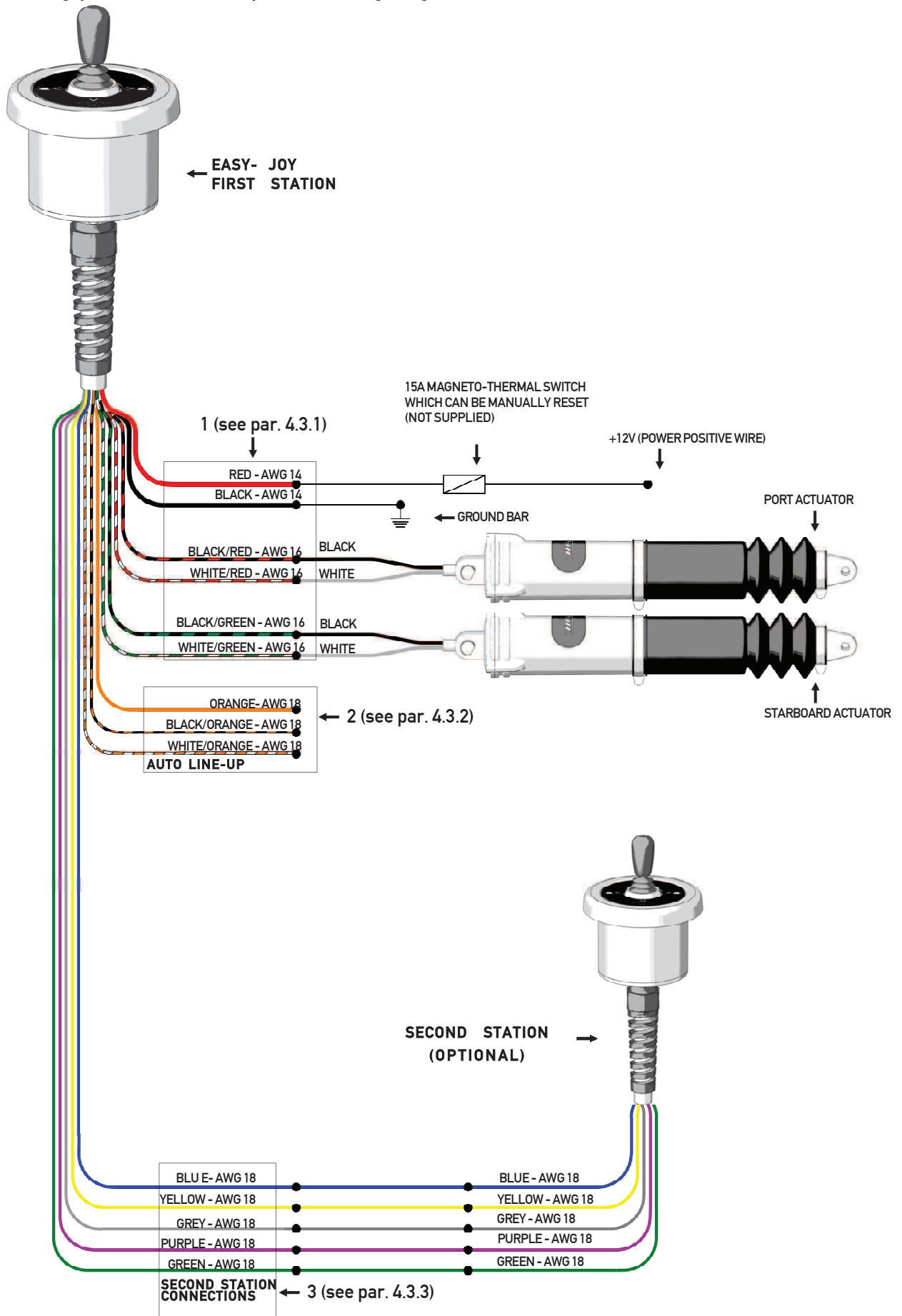

4.3.1 Actuator connection

ENGLISH

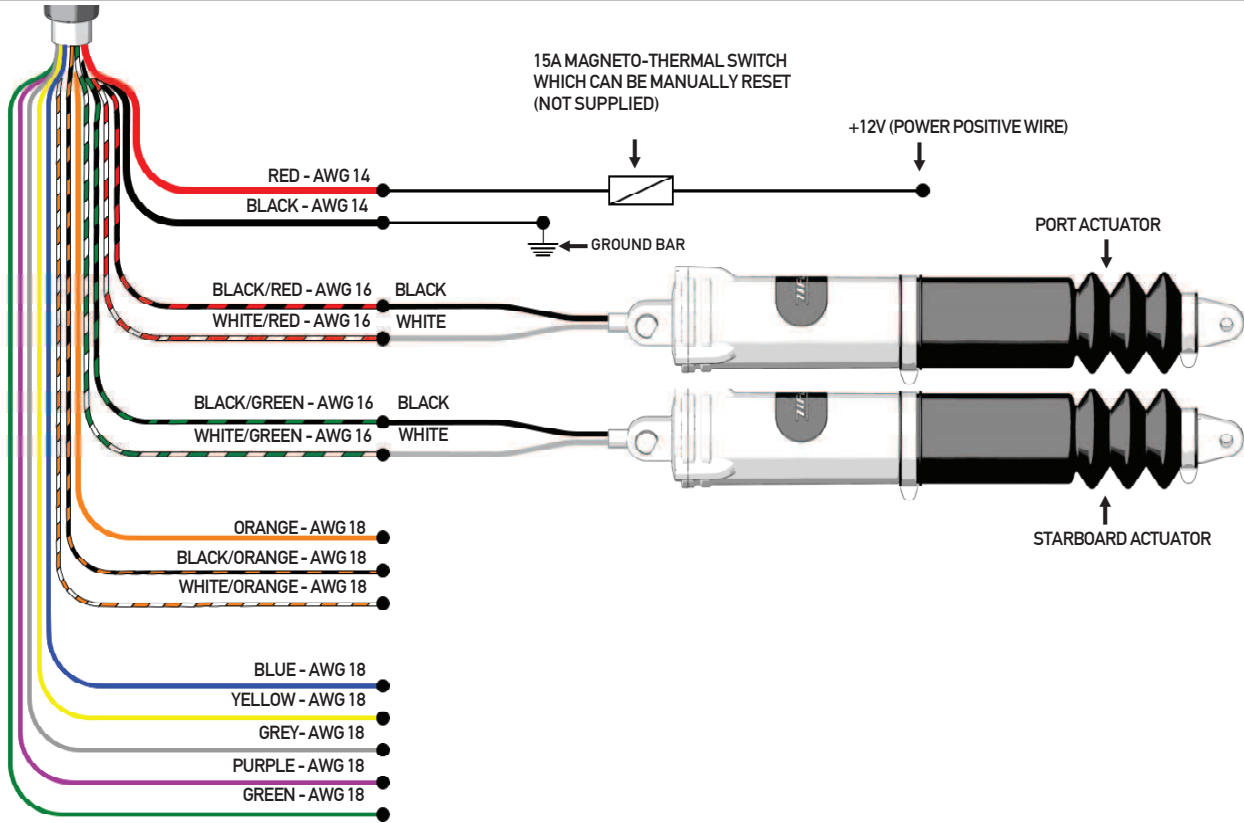

NOTE

In order to make installation easier, it is possible to use the general wiring including:

A – Power extension cable

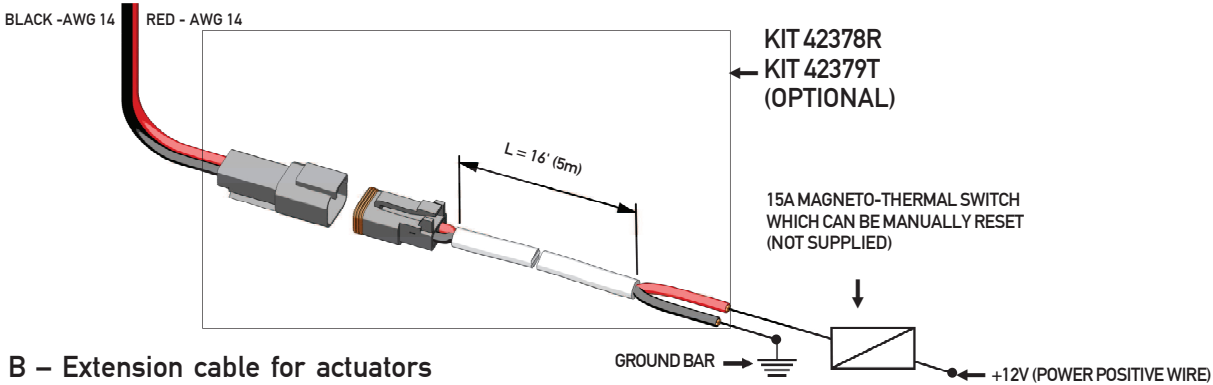

B – Extension cable for actuators

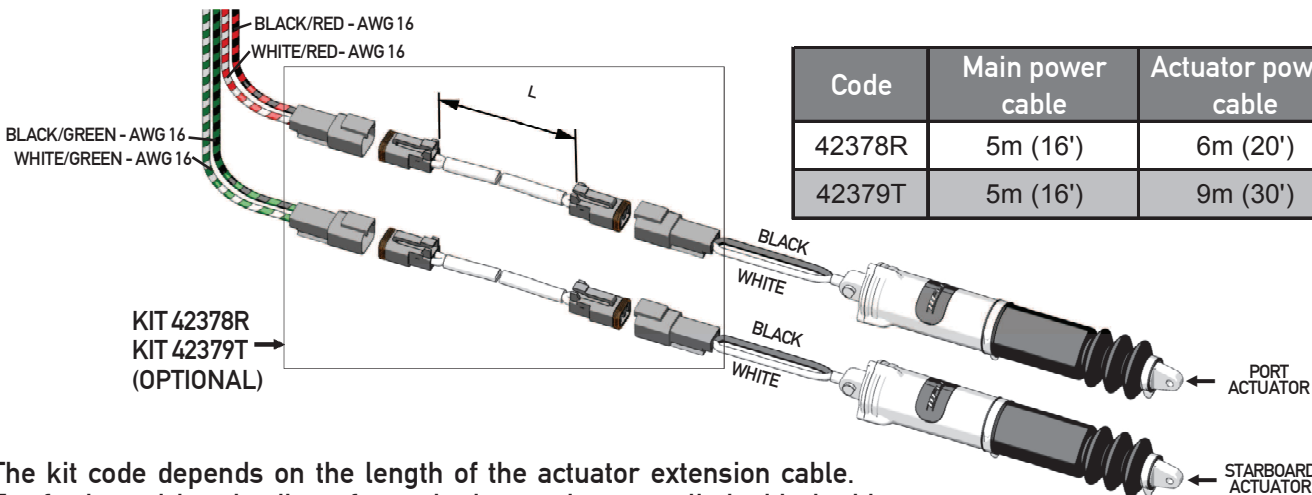

Code	Main power cable	Actuator power cable
42378R	5m (16')	6m (20')
42379T	5m (16')	9m (30')

The kit code depends on the length of the actuator extension cable. For further wiring details, refer to the instructions supplied with the kits.



4.3.2 Auto line-up

When running at idle or when the engine turns off, the auto line-up function allows putting the tabs in rest position automatically.
The auto line-up function can be enabled by means of the panel key or the neutral safety switch of the control unit.

Engine key:

Single engine

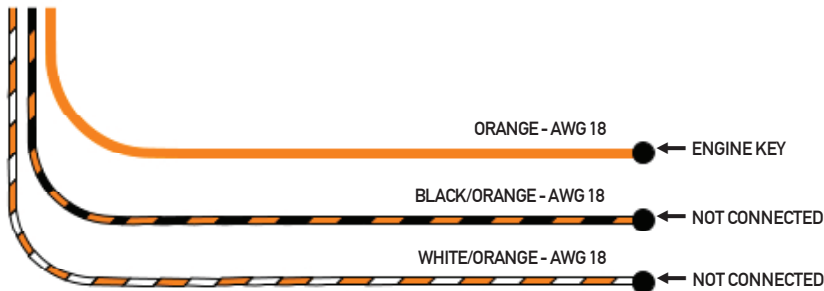

Twin engine

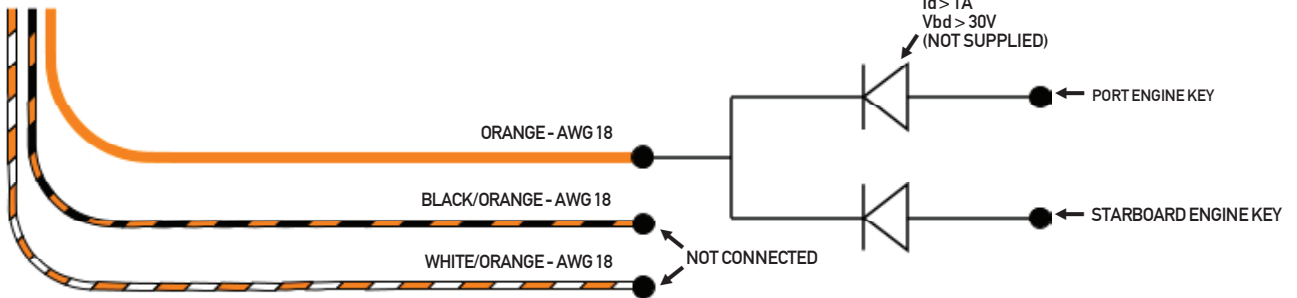

THE FOLLOWING WIRING KIT CAN BE USED

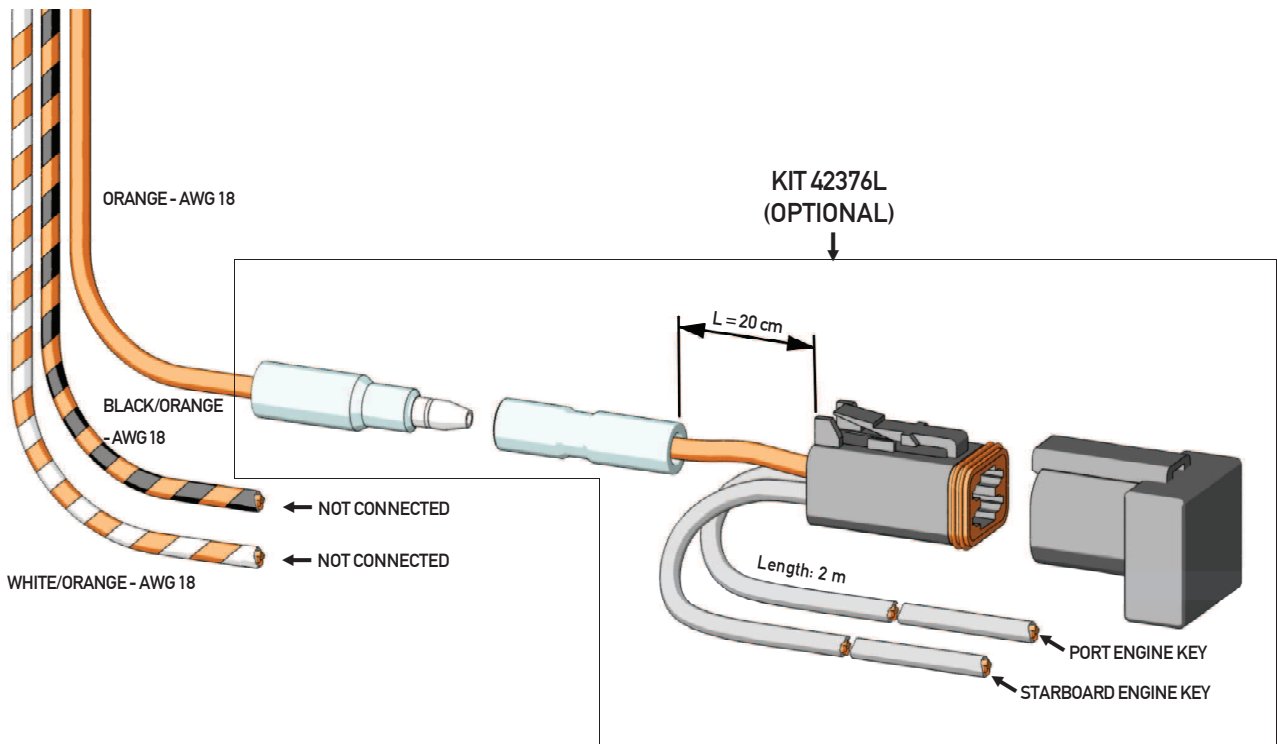

Neutral safety switch:

ENGLISH

Single engine

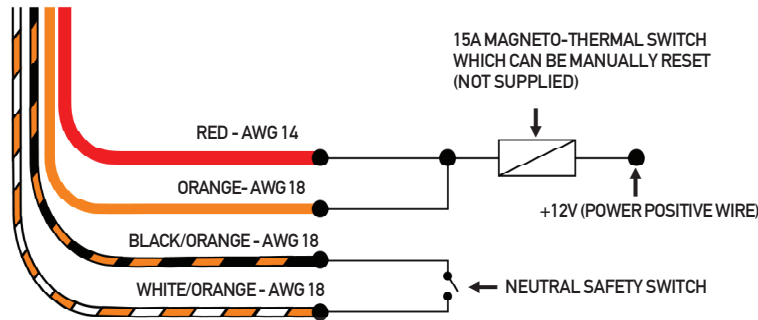

THE FOLLOWING WIRING KIT CAN BE USED

Single engine

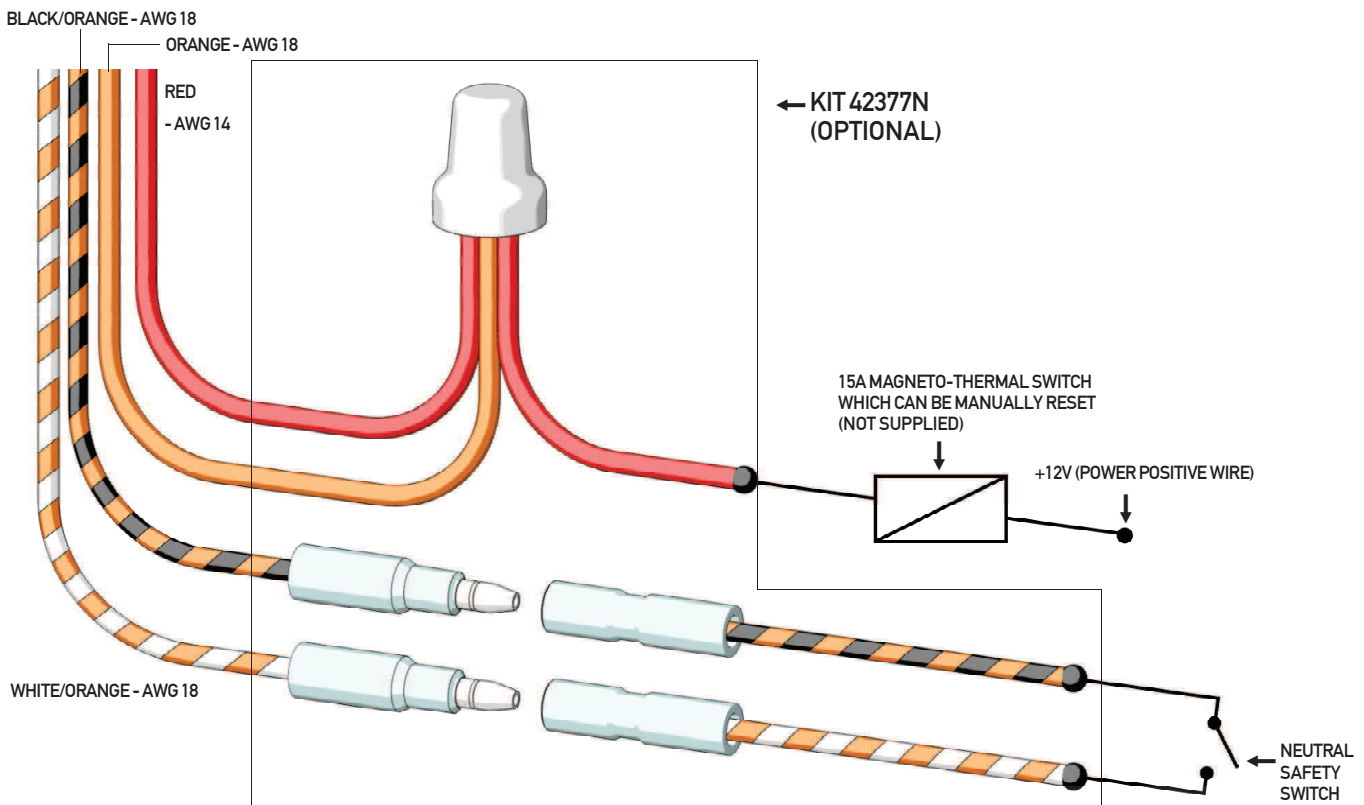

In case of twin engine boats with two different neutral safety switches, the auto line-up can be enabled in two different ways:

- A. The auto line-up is enabled when at least one of the two engines has not been put into gear
- B. The auto line-up is enabled when both engines have not been put into gear

Twin engine

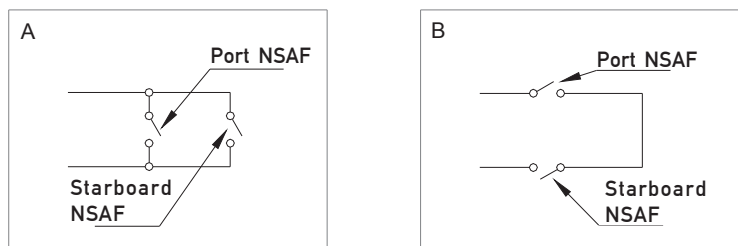

If the neutral safety switch has already been enabled, please contact the technical assistance service.



4.3.3 Connection of the second Easy-Joy control station

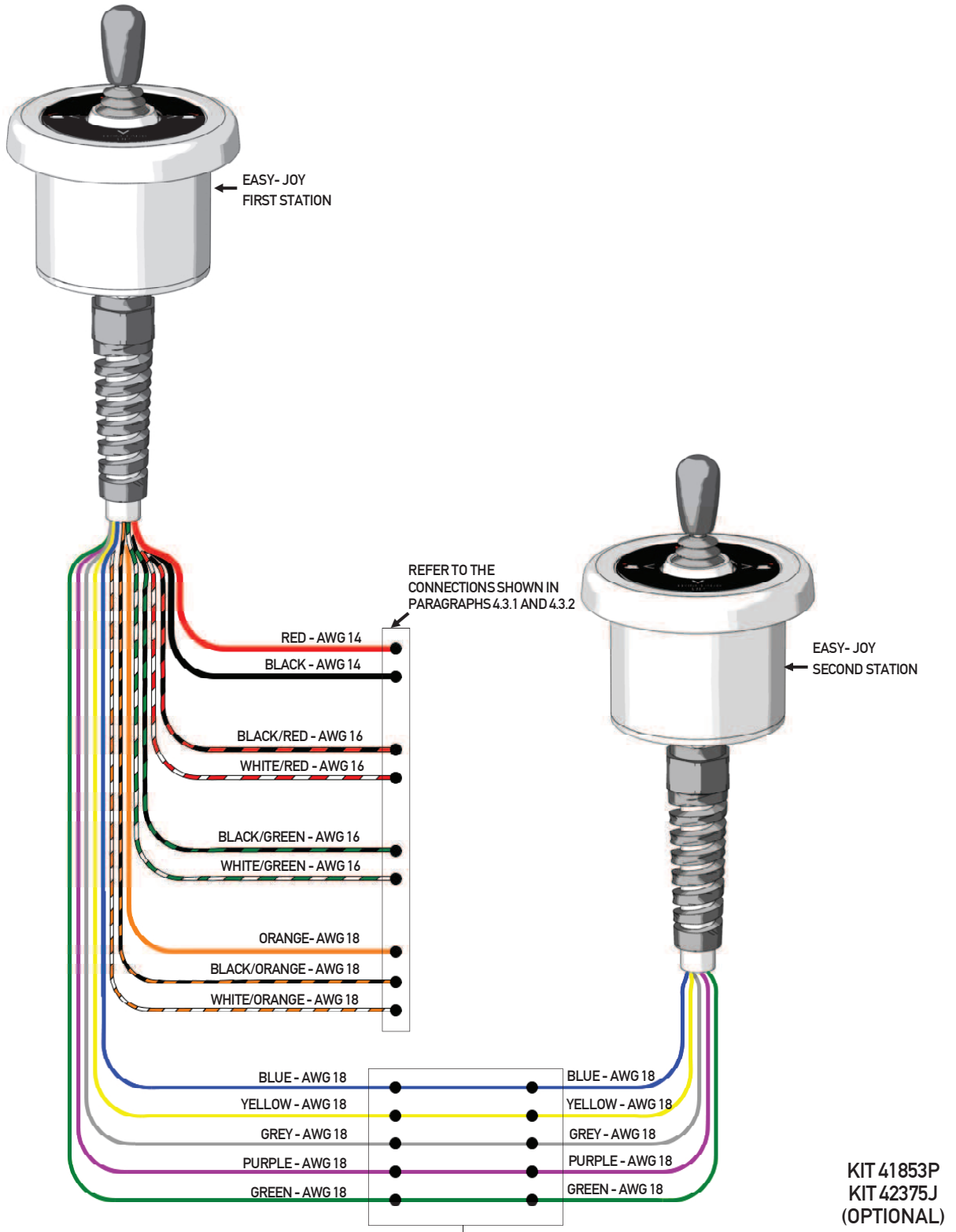

KIT 41853P
KIT 42375J
(OPTIONAL)

The kit code depends on the length of the extension cable for the second station. For further wiring details, refer to the instructions supplied with the kits.

L	Code
6m (20')	41853P
9m (30')	42375J

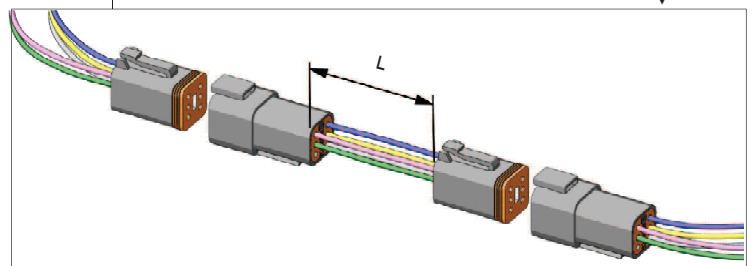

5 TRIM TAB USE

This section aims at describing the supplied appliance explaining the system operation so that it can be properly used. Please, read the manual carefully before using the **UFLEX** Trim Tab system.

This appliance is very easy to use, even for people who are not familiar with Trim Tab control systems and it allows improving sailing performances; the biggest advantage of the **UFLEX** system is that it can be used even by unskilled drivers.

5.1 Use

The system is made up of an **Easy-Joy** joystick, which allows controlling the electromechanical actuators. This innovative system allows changing the tab position by jogging the joystick, making it easier to change the boat trim.





Thanks to a combined movement of the two tabs which is controlled by the **Easy-Joy**, the user can focus on the boat trim, regardless of the tab position.

The lever can be put into four positions which enable the tab movement changing the boat trim.

- By jogging the lever forward, the boat bow goes down and the boat goes to planing position.
- By jogging the lever backward, the boat bow goes up, reducing the tab planing effect.
- If the boat trim is not correct and the boat tilts to starboard, by jogging the lever to the left, the system gives the boat a correct trim.
- If the boat trim is not correct and the boat tilts to port, by jogging the lever to the right, the system gives the boat a correct trim.

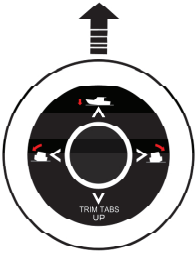
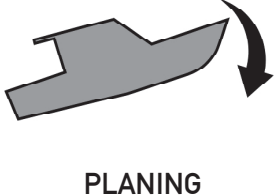
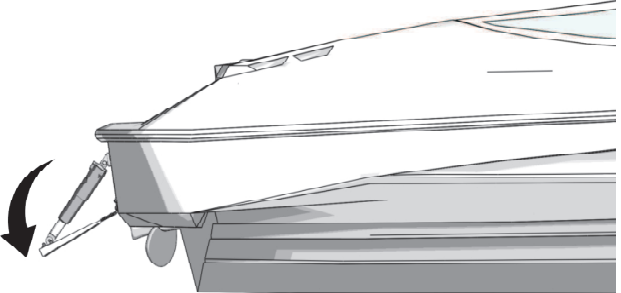
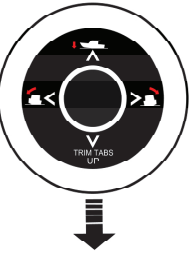
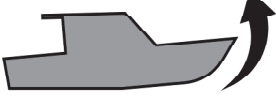
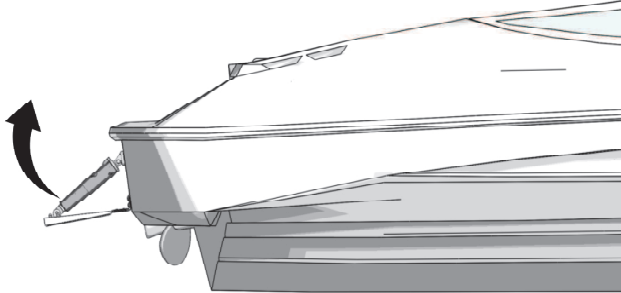
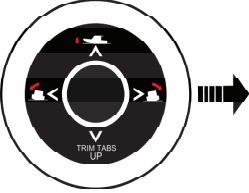
The table on the next page shows all the possible movements of the joystick lever, the changes to be made for a correct boat trim and the combined movement of the tabs.

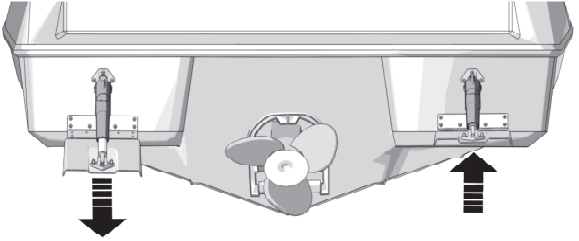
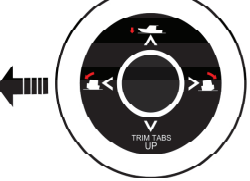

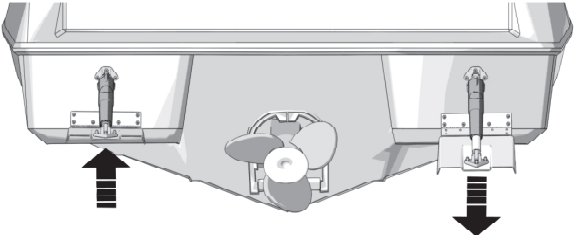
CHANGE WITH THE EASY-JOY	CHANGE	TAB MOVEMENT
	 <p>PLANING</p>	
		
		
		

The electronic system can automatically enable an important function named "Auto line-up" which allows aligning the tabs at rest, without using the **Easy-joy** control station. As explained in the wiring chapter, two different kinds of installation are available: engine key control or neutral safety switch control. This function is provided with an inhibition device that prevent it from being enabled again for five minutes; after this time has passed, the "Auto line-up" function is available again.

- Engine key

When the engine key is turned and the control panel is switched off, the system enables the "Auto line-up" function, putting the tabs in rest position.

- Neutral safety switch

When the lever is put in engine neutral condition, the Neutral safety switch connected to the lever sends a signal that enables the "Auto line-up" function, so that the actuators close and the tabs return to the rest position.



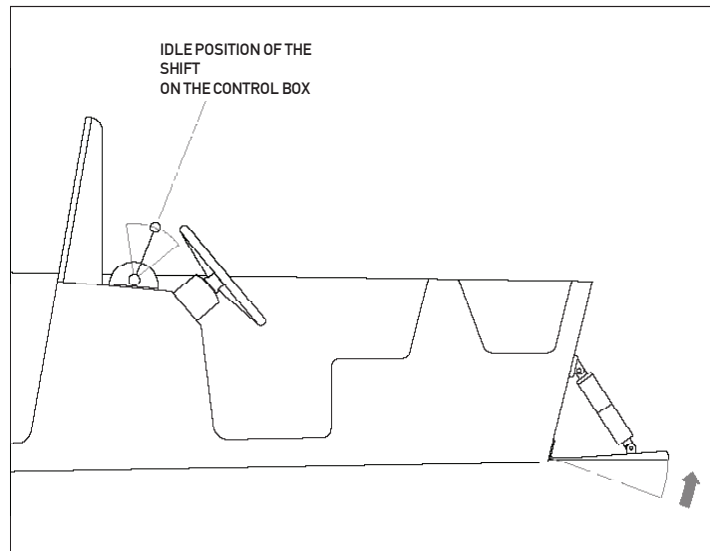

5.2 Safety rules during use

OBSERVE STRICTLY the following safety rules:

UFLEX declines all responsibility in case the user does not follow these rules and it is not responsible for negligence during the use of the system.

⚠ DANGER

- **DO NOT PUT YOUR HANDS BETWEEN THE MOVING PARTS**
- Do not disable the safety devices.
- Do not modify or add devices to the system, without **UFLEX** written authorisation or technical intervention which will prove the modification.
- Do not use the appliance for a purpose different from the one it has been designed for, which is specified in the installation and maintenance manual.
- Do not let non-specialized staff perform the installation.
- Before disassembling the electric connections, disconnect the appliance from the power sources.

⚠ WARNING

- In order to change the trim, jog the lever. Should the user move the lever continuously, the boat could side-skid due to the combined movement of the two tabs.
- While sailing at high speed, do not correct the boat trim excessively. This could cause sudden trim changes and consequently undesired turns.
- When in following seas or when running an inlet, the tabs should be fully retracted. This allows for optimal performance.
- While operating trim tabs, use caution. Improper use of trim tabs may cause accidents and/or injury.



6 MAINTENANCE

6.1 Ordinary maintenance



A proper maintenance is an important factor for a longer duration of the trim tabs in optimum working conditions and it ensures safety from a functional point of view. Only skilled and properly trained staff should carry out maintenance operations.

The design and the materials used to manufacture the trim tabs reduce maintenance operations to a minimum. The staff must be provided with individual protection means commonly used in similar operations and follow the safety rules described below.

WARNING

The main safety warnings to be observed during maintenance are:

- Do not wear rings, watches, small chains, armllets, etc. during maintenance operations.
- Always use individual protections means (gloves).
- Do not use free flames, points or pins for cleaning.
- Do not smoke.

WARNING

- During the boat seasonal maintenance and before the beginning of each season, check that:

- 1) Fixing screws are firmly fastened.
- 2) There is no marine growth on the actuator and on the mobile parts of the tabs.

NOTICE

To discourage any marine growth on tab, antifouling paint can be applied. When applying paint to the actuator, make sure it is fully retracted.

Technical Support

For any information or for assistance with special applications please contact our technical support staff (See paragraph "Informative Letter").



7 DISMANTLING

7.1 Dismantling

ENGLISH

When for any reason the system is put out of service, it is necessary to follow some rules in order to respect the environment.

Sheaths, pipelines, plastic or non-metallic components must be disassembled and disposed of separately.



Easy-Joy - Drilling template

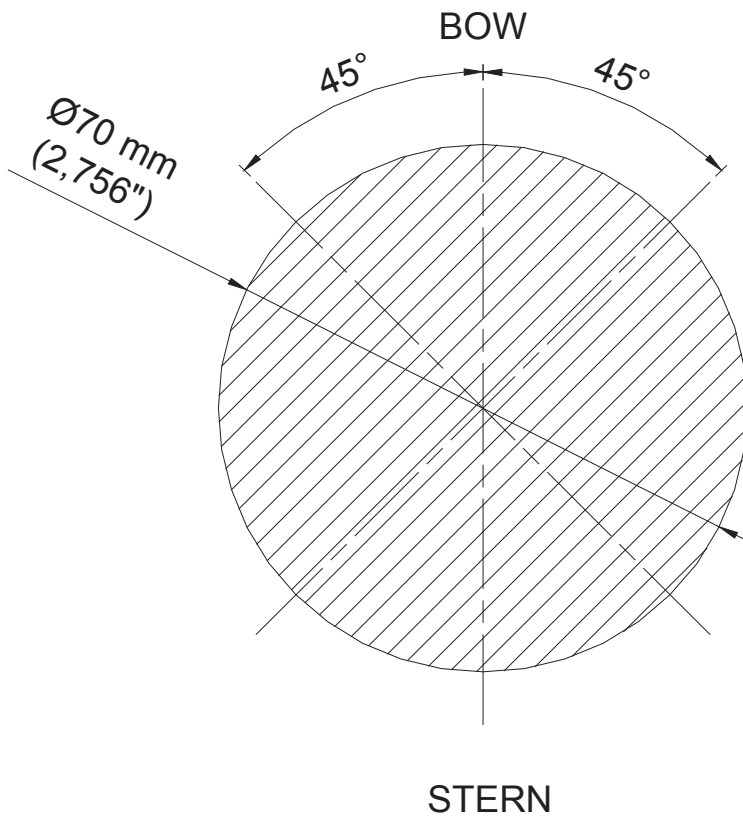

Full size scale

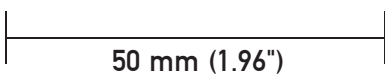

Easy-Joy - Gabarit de perçage

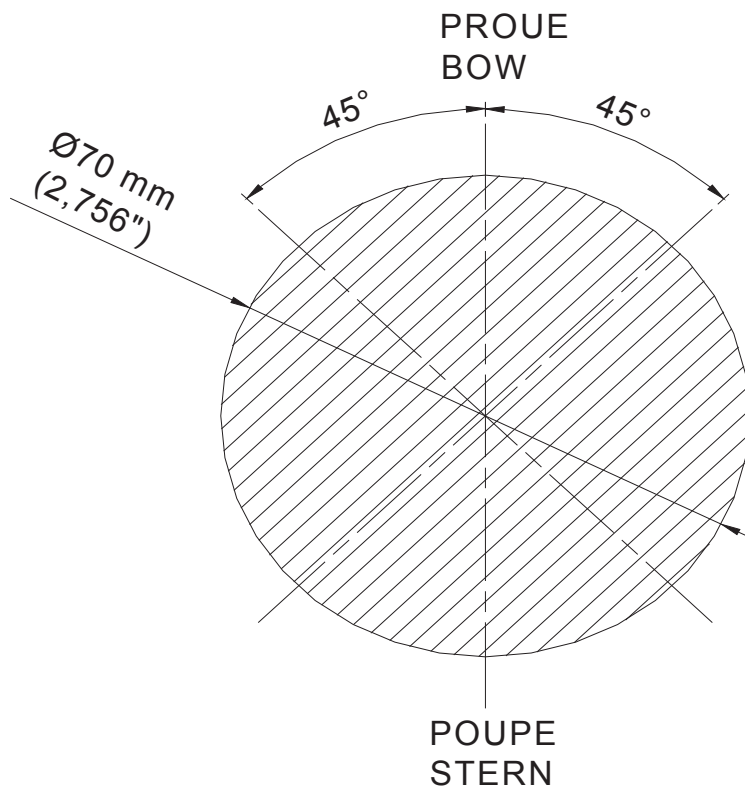

Echelle 1:1

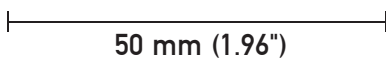

UFLEX

Via Milite Ignoto,8A 16012 Busalla (GE)-Italy